

PREPARED BY:  
PROJECT:  
TYPE:

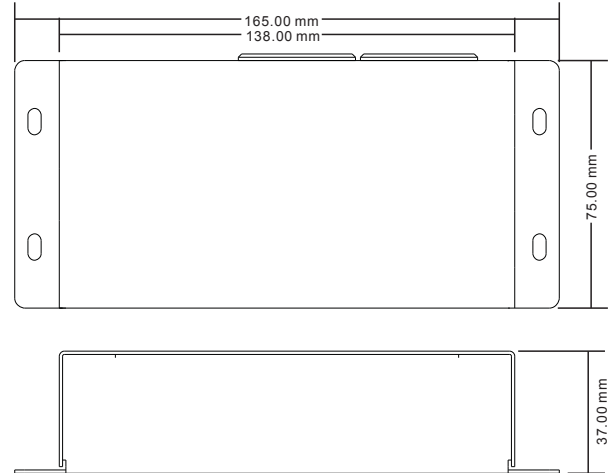

# Wall Mounted RGB/W DMX512 MASTER CONTROLLER SERIES



## FEATURES

- User-friendly interface, easy and simple operation
- Touch sensitive
- Standard DMX512 Signal output
- Can be controlled by RF / WiFi controller
- Control RGBW color
- Control 8 zones synchronously and separately
- Operation return function
- Preset 10 changing modes, with pause function
- Synchronization function of pattern changes ensure consistent change forever
- Control synchronously after installing app on IOS or Android system
- Enable to dim brightness of each R, G, B, W channel, in order to mix millions of colors
- Can be controlled by LB2819T100 / LB2820-US-100
- Memory function to remember the last color/scene

## SPECIFICATIONS

• Output	DMX512+WiFi signal	• Waterproof	IP20
• Power Supply	12VDC	• Relative humidity	8% to 80%
• Power Consumption	< 20 mA	• Dimensions	6.50" x 2.96" x 1.46" (165mm x 75mm x 37mm)
• Operating Temperature	0-40°C		

**\*Not compatible with magnetic drivers.**

## ORDERING GUIDE

Model	Description
LB2816	WALL MOUNTED RGB/W DMX512 MASTER



PREPARED BY:  
PROJECT:  
TYPE:



# Wall Mounted RGB/W DMX512 MASTER CONTROLLER SERIES

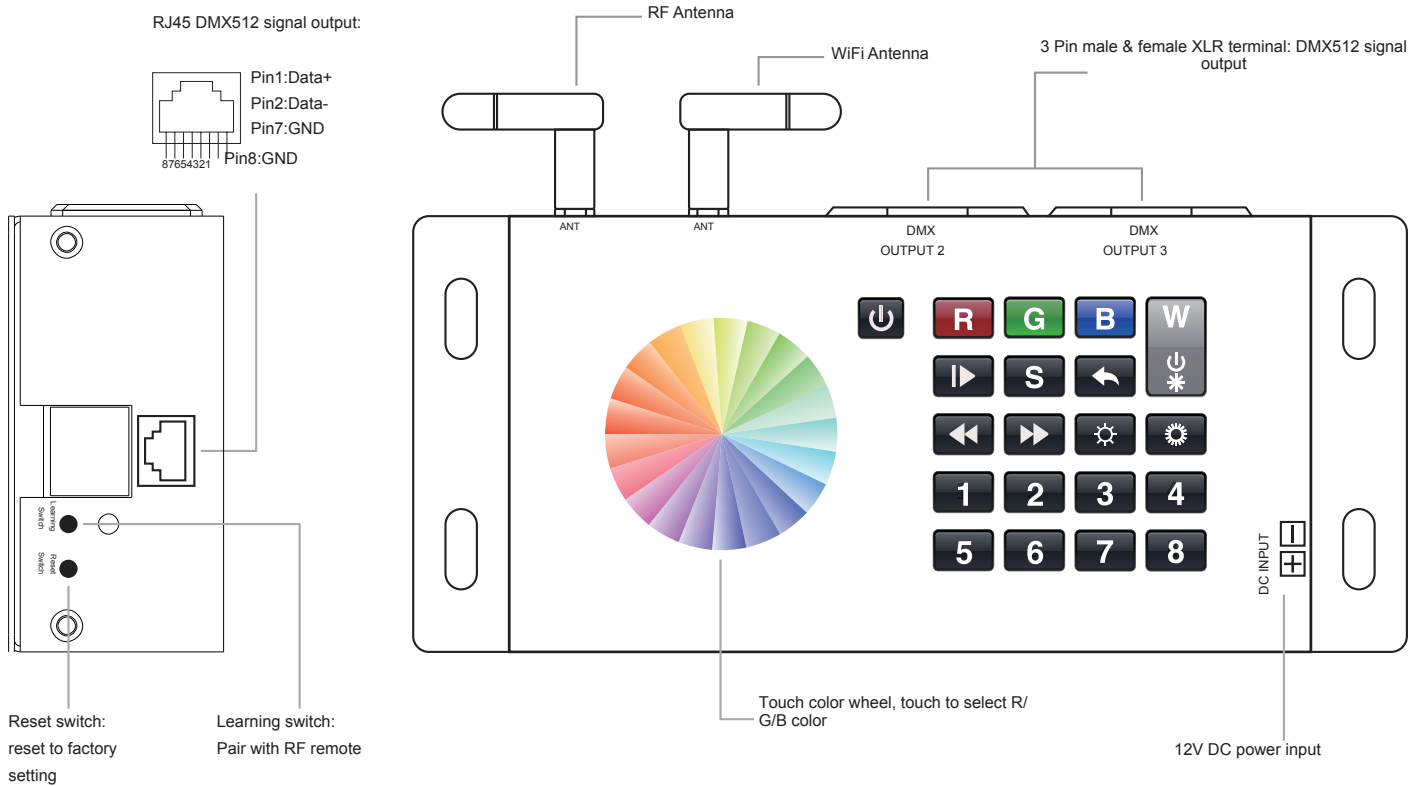

- Click to switch ON/OFF
- Red channel:Click to turn off/on, Press and hold down to increase/decrease light intensity
- Green channel:Click to turn off/on, Press and hold down to increase/decrease light intensity
- Blue channel:Click to turn off/on, Press and hold down to increase/decrease light intensity
- White channel:Click to turn off/on, Press and hold down to increase/decrease light intensity
- Play & pause mode, click to play or pause running mode
- Save color, press and hold down to save, click to recall the saved
- Return to previous status
- Speed down, press and hold down to speed down the running mode
- Speed up, press and hold down to speed up the running mode
- Brightness down, press and hold down to decrease light intensity
- Brightness up, press and hold down to increase light intensity
- 8 zones, click to select a zone, press and hold down to turn on/off corresponding zone

PREPARED BY:  
PROJECT:  
TYPE:



# Wall Mounted RGB/W DMX512 MASTER CONTROLLER SERIES

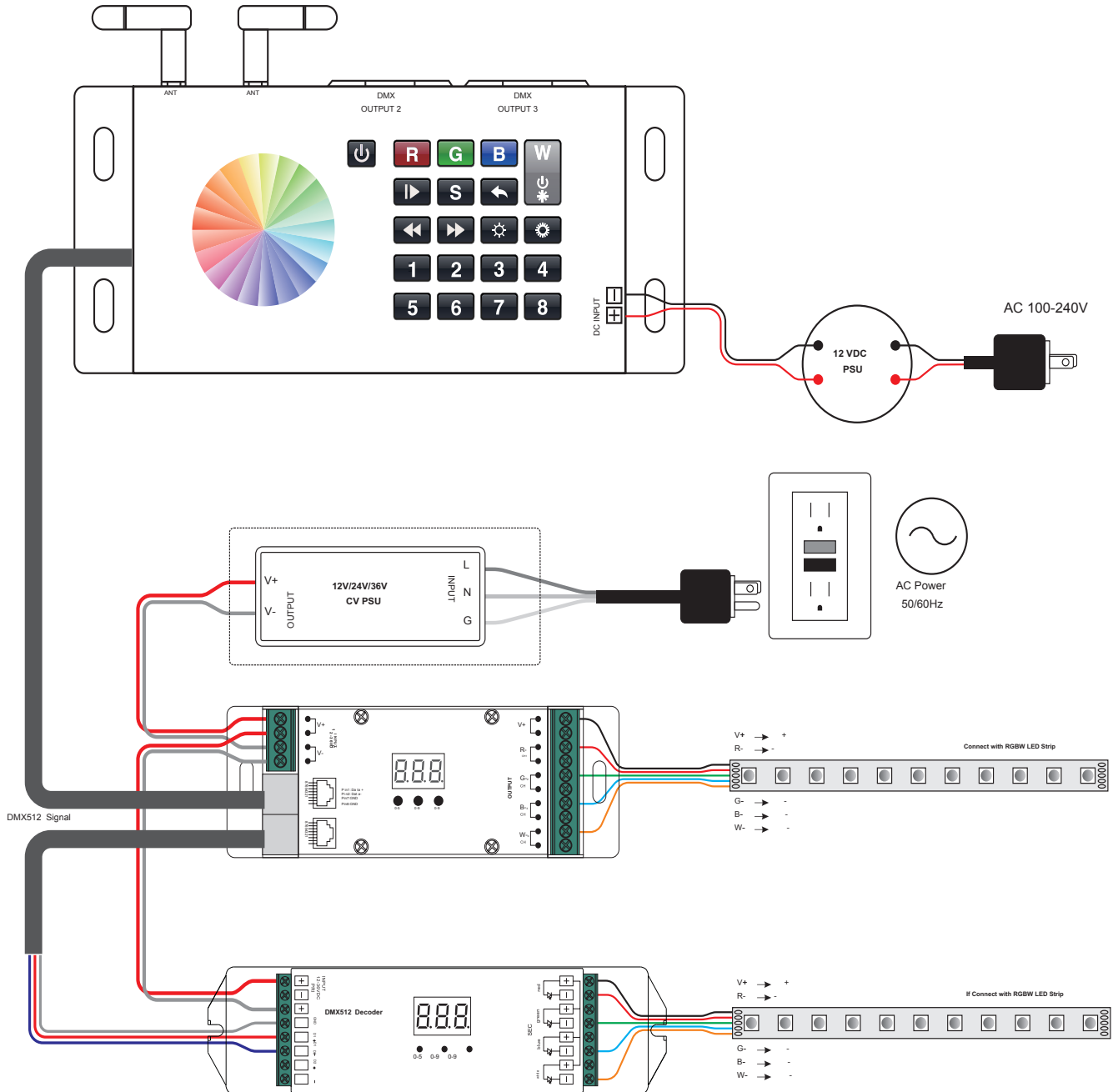

PREPARED BY:  
PROJECT:  
TYPE:



# Wall Mounted RGB/W DMX512 MASTER CONTROLLER SERIES

**Do wiring according to connection diagram.**

## Set DMX Address

This DMX master controller controls up to 8 zones of decoders by setting DMX decoders' address as follows:

DMX decoders with address 001 will be controlled by zone 1,  
DMX decoders with address 005 will be controlled by zone 2,  
DMX decoders with address 009 will be controlled by zone 3,  
DMX decoders with address 013 will be controlled by zone 4,  
DMX decoders with address 017 will be controlled by zone 5,  
DMX decoders with address 021 will be controlled by zone 6,  
DMX decoders with address 025 will be controlled by zone 7,  
DMX decoders with address 029 will be controlled by zone 8.

Each zone can pair endless of DMX decoders if you set the address accordingly.

## Pair DMX Master with RF Remote :

Power on DMX master and turn on the remote → Click one of the paired zone numbers:1-8 → Click the **“Learning Key”** button on DMX master, the **indicator** on the DMX master will turn on

→ Touch the color wheel on the remote → The connected LED lights with DMX decoder will blink, which means well paired.

## Save color/scene/mode:

Turn on DMX master → Click one of the paired zone numbers → Operation the buttons to select a color /mode you like → Press and hold down button **S** until the LED indicator flashes once

→ Immediately click any of the zone numbers that you would like to save the color/scene to → The connected LED light with DMX decoder will flash → The color/scene is saved successfully.

## Recall the saved colors/scenes:

Turn on DMX master → Click any of the zone numbers you would like to recall the scene/color → Click button **S** → Click the zone number again to recall the saved.

## How to delete the pairing:

Power on DMX master → Press and hold down **“Learning Key”** on the master for over 3 seconds until connected LED lights with the DMX decoder blink twice, which means the pairing is deleted successfully.

## WiFi Control via APP installed on IOS or Android system

**This DMX master controller can be WiFi controlled via APP installed on IOS or Android system, please follow the instructions below:**

- 1) Search and download “EasyLighting” APP from APP Store or Google Play on your mobile device.
- 2) Wire up the controller correctly according to wiring diagram and power on.
- 3) Search and connect your mobile device WLAN to the controller network “EasyLighting”. Password is 0123456789.
- 4) Run “EasyLighting” APP on your mobile device. Please refer to the user manual of “EasyLighting” APP to learn how to pair and control.

**WiFi Reset Button:** Once configured to your home router, the controller can be controlled via your wireless home network by connecting the mobile device WLAN to your wireless home network. The “WiFi reset” button is used to factory reset the WiFi setting of the controller if you would like to directly control it again via “EasyLighting” network.